

EV-26L

Model		EV-26L
Rated output	ps	50(68)
	rpm	2500
Max. Torque	kgf.m	19.9
	rpm	1600
Compression ratio		10.5:1
Displacement (l)		2.607
No. of cylinder		4 - inline
Aspiration		Natural Aspiration
Combustion type		Stoichiometric
Fuel		LPG (Propane)
Dimension(mm)		692x609x658
Dry Weight(kg)		200
Flywheel		SAE #10
Flywheel Housing		SAE #4

■ Engine Configuration & Dimensions

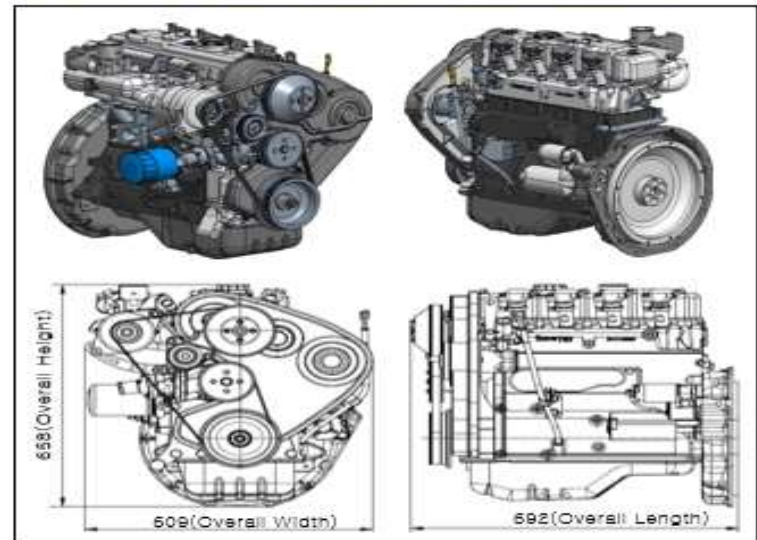

■ Performance Curve

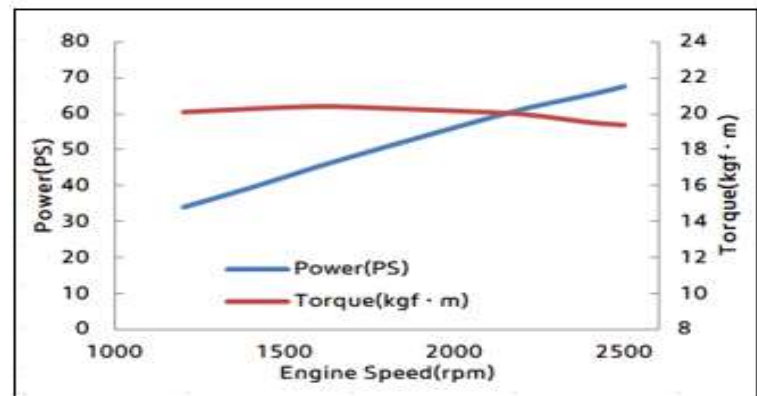

The engine performance corresponds to ISO 3046 (Without a cooling fan). The product images shown are for illustration only and may not be an exact representation of the final product. All information is subject to change without notice.